

TB & TRA SERIES

High Accuracy Specialty Sensors



The TB strap-on sensor uses a clamp to secure the unit to a pipe and a copper sensing plate for fast temperature response. The TB is perfect for secondary measurement of water temperature typical in retrofit applications. It includes a steel mounting box for wire termination and easy conduit connection.

The TRA Series stainless steel remote probe is designed for high accuracy in remote temperature sensing applications. The TRA can be used in numerous refrigeration applications or can be mounted on pipes for chilled or heated water temperature sensing. It is easily installed and includes a durable stainless steel sensing probe and a two-wire twisted pair cable with strain relief. Multiple cable lengths are available for added flexibility.

SPECIFICATIONS

TB & TRA Series

Wiring	22 AWG; 2-wire: RTD/Thermistor
LINITEMP OPTION	
Input Power	Class 2; 5 to 30 Vdc
Output	10mV/°C
Calibration Offset	1.5 °C (2.7 °F) typical; 2.5 °C (4.5 °F) max. at 25 °C (77 °F)*
Offset Over Temperature	1.8 °C (3.24 °F) typical; 3.0 °C (5.4 °F) max. over 0 to 70 °C (32 to 158 °F) range; 2.0 °C (3.6 °F) typical, 3.5 °C (6.3 °F) max. over -25 to 105 °C (-13 to 221 °F) range
Operating Temperature	-25 to 105 °C (-13 to 221 °F)
TB	Probe: -25 to 105 °C (-13 to 221 °F),
TRA	Wiring: -20 to 80 °C (-4 to 176 °F)
WARRANTY	
Limited Warranty	5 years

*Room temperature offset documented on each unit.

Note: See page 202 for thermistor table.

Secondary measurement

Secondary measurement of water temperature...ideal for retrofit applications (TB)

Easy installation

Pipe clamps allow for easy installation on pipes up to 12" in diameter (TB)

Long sensor life

Durable stainless steel sensing probe (TRA)

Multiple cable lengths

Multiple cable lengths for application flexibility (TRA)

TRA
Dimensional Drawing

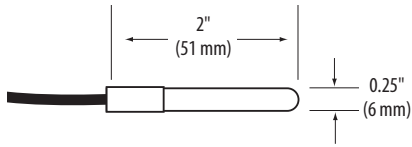

TB
Dimensional Drawing

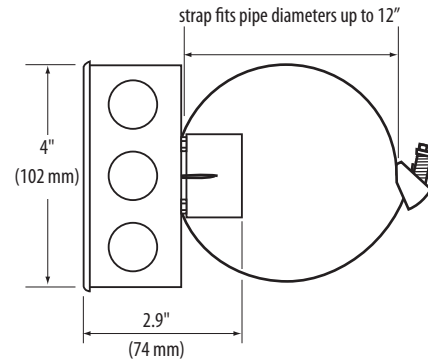

ORDERING INFORMATION

Strap-on Bracket

Diameter	Sensor Type	Calibration Certificate
TB <input type="checkbox"/>	<input type="checkbox"/>	<input type="checkbox"/>
A = 2 1/2" (6.4 cm) max. D = 8" (20 cm) max. E = 12" (31 cm) max.	B = 100R platinum, RTD C = 1k platinum, RTD D = 10k T2, Thermistor E = 2.2k, Thermistor F = 3k, Thermistor G = 10k CPC, Thermistor H = 10k T3, Thermistor I = 1k Balco (Nickel-iron) RTD J = 10k Dale, Thermistor K = 10k w/11k shunt, Thermistor M = 20k NTC, Thermistor N = 1800 ohm, Thermistor P = 10mV/°C, Linitemp R = 10k US, Thermistor S = 10k 3A221, Thermistor T = 100k, Thermistor U = 20k "D", Thermistor W = 10k T2 high accuracy, Thermistor Y = 10k T3 high accuracy, Thermistor	0 = None 1 = 1-point cal validation* 2 = 2-point cal validation*

* Not available with W and Y high-accuracy thermistors.

Remote Probe

Sensor Type	Calibration Certificate	Cable Length
TRA <input type="checkbox"/>	<input type="checkbox"/>	<input type="checkbox"/>
B = 100R platinum, RTD C = 1k platinum, RTD D = 10k T2, Thermistor E = 2.2k, Thermistor F = 3k, Thermistor G = 10k CPC, Thermistor H = 10k T3, Thermistor I = 1k Balco (Nickel-iron) RTD J = 10k Dale, Thermistor K = 10k w/11k shunt, Thermistor M = 20k NTC, Thermistor N = 1800 ohm, Thermistor P = 10mV/°C, Linitemp R = 10k US, Thermistor S = 10k 3A221, Thermistor T = 100k, Thermistor U = 20k "D", Thermistor W = 10k T2 high accuracy, Thermistor Y = 10k T3 high accuracy, Thermistor	0 = None 1 = 1-point cal validation † 2 = 2-point cal validation †	None = 3 ft (0.9 m) A = 6 ft (1.8 m)*** B = 10 ft (3.1 m)* C = 20 ft (6.1 m)** D = 25 ft (7.6 m)** E = 50 ft (15 m)** F = 100 ft (30 m)**

Examples:

TB	<input type="checkbox"/> D	<input type="checkbox"/> C	<input type="checkbox"/> 2
TRA	<input type="checkbox"/> F	<input type="checkbox"/> 1	

*Not available for sensor types B, C & P.
**Not available for sensor types B, C, E, F, N & P.
***Not available for sensor types B & P.
† Not available with W and Y high-accuracy thermistors.



THERMISTOR TABLE

Class	Pt RTD		Balco RTD	THERMISTOR				
	100 Ohm	1000 Ohm	1000 Ohm	10k Type 2	10k Type 3	10k Dale	10k "G" US	20k
Accuracy	±0.3°C	±0.3°C	±1% @70°C	±1.0°C	±0.2°C	±0.2°C	±0.2°C	Consult
	0.00385 curve	0.00385 curve		-50/150°C	0/70°C	-20/70°C	0/70°C	Factory
Temp. Response*	PTC	PTC	PTC	NTC	NTC	NTC	NTC	NTC

*PTC: Positive Temperature Coefficient *NTC: Negative Temperature Coefficient

STANDARD RTD AND THERMISTOR VALUES (Ohms Ω)

°C	°F	100 Ohm	1000 Ohm	1000 Ohm	10k Type 2	10k Type 3	10k Dale	10k "G" US	20k NTC
-50	-58	80.306	803.06	740.46	692,700	454,910	672,300	441,200	1,267,600
-40	-40	84.271	842.71	773.99	344,700	245,089	337,200	239,700	643,800
-30	-22	88.222	882.22	806.02	180,100	137,307	177,200	135,300	342,000
-20	-4	92.160	921.60	841.00	98,320	79,729	97,130	78,910	189,080
-10	14	96.086	960.86	877.46	55,790	47,843	55,340	47,540	108,380
0	32	100.000	1,000.00	913.66	32,770	29,588	32,660	29,490	64,160
10	50	103.903	1,039.03	952.25	19,930	18,813	19,900	18,780	39,440
20	68	107.794	1,077.94	991.82	12,500	12,272	12,490	12,260	24,920
25	77	109.735	1,097.35	1,013.50	10,000	10,000	10,000	10,000	20,000
30	86	111.673	1,116.73	1,035.18	8,055	8,195	8,056	8,194	16,144
40	104	115.541	1,155.41	1,077.68	5,323	5,593	5,326	5,592	10,696
50	122	119.397	1,193.97	1,120.52	3,599	3,894	3,602	3,893	7,234
60	140	123.242	1,232.42	1,166.13	2,486	2,763	2,489	2,760	4,992
70	158	127.075	1,270.75	1,210.75	1,753	1,994	1,753	1,990	3,512
80	176	130.897	1,308.97	1,254.55	1,258	1,462	1,258	1,458	2,516
90	194	134.707	1,347.07	1,301.17	919	1,088	917	1,084	1,833
100	212	138.506	1,385.06	1,348.38	682	821	679	816.8	1,356
110	230	142.293	1,422.93	1,397.13	513	628	511	623.6	1,016
120	248	146.068	1,460.68	1,447.44	392	486	389	481.8	770
130	266	149.832	1,498.32	1,496.28	303	380	301	376.4	591
Sensor Codes		B	C	I	D	H	J	R	M

To compute Linitemp Temperature
 mV reading/10 - 273.15 = Temperature in °C

